

# Wirbelbock-Gewinde

## > VWBG <

### in pink



## Safety instructions

This safety instruction/declaration has to be kept on file for the whole lifetime of the product.

Translation of the original safety instruction



**RUD Ketten**  
**Rieger & Dietz GmbH u. Co. KG**  
 73428 Aalen  
 Tel. +49 7361 504-1351-1370-1262  
 Fax +49 7361 504-1460  
 info@rud.com  
 www.rud.com

RUD-Art.-Nr.: 8503693-EN / 01.013



Wirbelbock-Gewinde

**EG-Konformitätserklärung**

entsprechend der EG-Maschinenrichtlinie 2006/42/EG, Anhang II A und ihren Änderungen

Hersteller: **RUD Ketten  
Rieger & Dietz GmbH u. Co. KG**  
Friedensinsel  
73432 Aalen

Hiermit erklären wir, dass die nachfolgend bezeichnete Maschine aufgrund ihrer Konzeption und Bauart, sowie in der von uns in Verkehr gebrachten Ausführung, den grundlegenden Sicherheits- und Gesundheitsanforderungen der EG-Maschinenrichtlinie 2006/42/EG sowie den unten aufgeführten harmonisierten und nationalen Normen sowie technischen Spezifikationen entspricht.  
Bei einer nicht mit uns abgestimmten Änderung der Maschine verliert diese Erklärung ihre Gültigkeit.

Produktbezeichnung: Wirbelbock  
VWBG-V / VWBG / WBG

Folgende harmonisierten Normen wurden angewandt:

EN 12100	EN 1677-1
EN 1677-4	

Folgende nationalen Normen und technische Spezifikationen wurden außerdem angewandt:

BGR 500, KAP2.8	

Für die Zusammenstellung der Konformitätsdokumentation bevollmächtigte Person:  
Reinhard Smetz, RUD Ketten, 73432 Aalen

Aalen, den 03.01.2013 Dr. Ing. Rolf Sinz (Prokurist/OMB)  
Name, Funktion und Unterschrift Verantwortlicher

**EC-Declaration of conformity**

According to the EC-Machinery Directive 2006/42/EC, annex II A and amendments

Manufacturer: **RUD Ketten  
Rieger & Dietz GmbH u. Co. KG**  
Friedensinsel  
73432 Aalen

We hereby declare that the equipment sold by us because of its design and construction, as mentioned below, corresponds to the appropriate, basic requirements of safety and health of the corresponding EC-Machinery Directive 2006/42/EC as well as to the below mentioned harmonized and national norms as well as technical specifications.  
In case of any modification of the equipment, not being agreed upon with us, this declaration becomes invalid.

Product name: Load ring  
VWBG-V / VWBG / WBG

The following harmonized norms were applied:

EN 12100	EN 1677-1
EN 1677-4	

The following national norms and technical specifications were applied:

BGR 500, KAP2.8	

Authorized person for the configuration of the declaration documents:  
Reinhard Smetz, RUD Ketten, 73432 Aalen

Aalen, 03.01.2013 Dr. Ing. Rolf Sinz (Prokurist/OMB)  
Name, function and signature of the responsible person



Before initial usage of the RUD VWBG hoist rings please read carefully the safety instructions. Make sure that you have understood all subjected matters. Non-observance can lead to serious personal injuries and material damage and eliminates warranty.

## 1 Safety instructions



### ATTENTION

Wrong assembled or damaged lifting points as well as improper use can lead to injuries of persons and damage of objects when load drops.

Please inspect all lifting points before each use.

- Not suitable for permanent turning operations under load. Lifting point cannot be turned 90° to the bolt-on direction under full load.
- Ball bearing must not be disassembled.
- The load ring must not be bend.
- RUD VWBG lifting points must only be used by instructed and competent persons considering BGR 500 and outside Germany noticing the country specific statutory regulations.

## 2 Intended use of VWBG

RUD VWBG lifting points must only be used for the assembly at the load or at lifting means.

They are intended to be hinged into lifting means and can be turned under load, but not under full load, especially not in the 90° direction.

RUD VWBG lifting points can also be used as lashing points to attach lashing means.

RUD VWGB lifting points must only be used in the hereby described operation purpose.

## 3 Assembly- and instruction manual

### 3.1 General information

- Capability of temperature usage:  
Usage at higher temperatures is not recommended due to the grease filling in the ball bearing. Should this though be necessary, the working load limit (WLL) of the VWBG must be reduced as follows:
  - -40°C up to 200°C no reduction
  - 200°C up to 300°C minus 10 %
  - 300°C up to 400°C minus 25 %
 Temperatures exceeding 400°C are prohibited!

- RUD VWBG lifting points must not be used with aggressive chemicals such as acids, alkaline solutions and their vapours.
- Please mark mounting position of lifting point with a coloured contrast paint for better visibility.

### 3.2 Hints for the assembly

Basically essential:

- The material construction to which the lifting point will be attached should be of adequate strength to withstand forces during lifting without deformation. The German testing authority BG, recommends the following minimum for the bolt lengths:
  - 1 x M (thread diameter) in steel (min. quality 235JR [1.0037])
  - 1.25 x M (thread diameter) in cast iron (e.g. GG 25)
  - 2 x M (thread diameter) in aluminium
  - 2.5 x M (thread diameter) in light alloys of low strength (M = thread size/diameter, e.g. M20)
- When lifting light metals, nonferrous metals and gray cast iron the thread has to be chosen in such a way that the WLL of the thread corresponds to the requirements of the base material.
- The position of the lifting points must be carried out in such a way that unintended movement like turning or flipping will be avoided.
  - For single leg lifts, the lifting point should be vertically above the centre of gravity of the load.
  - For two leg lifts, the lifting points must be equidistant to/or above the centre of gravity of the load.
  - For three and four leg lifts, the lifting points should be arranged symmetrical around the centre of gravity, in the same plane if possible.

- Load symmetry:

Determine the necessary WLL of each lifting point for a symmetrical or an unsymmetrical load by using the following physical calculation formula:

$$W_{LL} = \frac{G}{n \times \cos \beta}$$

W<sub>LL</sub> = necessary WLL of lifting point / single strand  
 G = weight of load  
 n = number of load bearing strands  
 β = inclination angle of single strand

Number of load bearing strands:

	Symmetric	Unsymmetric
two leg	2	1
three / four leg	3	1

Chart 1: Load bearing strands

- A plane surface must be guaranteed. Countersink of the tapped hole = Nominal diameter of thread + 4 mm. Blind holes must be drilled deep enough, that the bearing surface of the VWBG has full support.
- Due to the ball bearing it is sufficient for a single lift to tighten the VWBG until the bearing surface has support by using a spanner acc. to DIN 895 resp. DIN 894, without using an extension. If the VWBG shall permanently installed at the load, tensioning must be carried out with a torque (+/- 10 %) according to chart 2.
- Check finally the correct assembly (see chapter 4, test criteria).

### 3.3 User instructions

- Check frequently and before each initial operation the whole lifting mean in regard of linger ability as a lifting mean, regarding corrosion, wear, deformation etc. (see chapter 4, test criteria).



#### ATTENTION

*Wrong assembled or damaged lifting means as well as improper use can lead to injuries of persons and damage of objects when load falls. Please inspect all lifting points before each use.*

- VWBGs are suitable for turning and flipping of loads. In doing so, all positions of the ring can occur. The stated WLL at the lifting point is given for the most inappropriate possible case of operation (see picture 3 – part X). When ring has been adjusted manually (see picture Y) the higher (WLL) values from chart 3 can be used



#### ATTENTION

*Pay attention during the usage that the load type will not be change*

If the VWBG is will be loaded only perpendicular (in axial direction of the thread, see picture 3-part Z) the corresponding WLL values from chart 3 (inclination angle 0°) can be used.

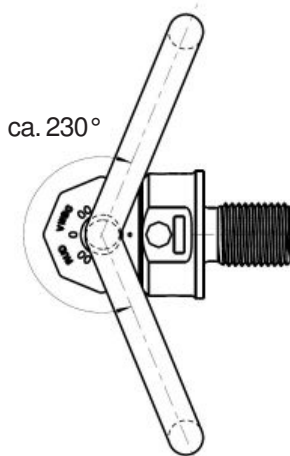

Pic. 1: Pivoting area

- The ring of the manually adjusted VWBG can be pivoted by approx. 230° (see picture 1).



#### ATTENTION

*The suspension ring resp. the attached lifting mean must rotate and pivot without interference during lifting and must **neither** have support at the load edge **nor** at the bottom part of the VWBG (see picture 2).*

- When lifting means (sling chains) are hinged or unhinged, no pinching, shearing or joint spots must occur during the handling. Avoid damage of lifting means resulting from sharp edges.
- Leave direct danger zone as far as possible.
- Watch always your hinged loads.
- Avoid impulsive and tiltful loading.



#### ATTENTION

*Impulsive loading or vibration, especially at through hole connections with nuts, can lead to unintentional loosening.*

Securing possibilities: liquid thread securing products f.e. Loctite (read manufacturer's instruction) or form closed bolt securing such as a crown nut with split pin, lock nut etc. can be used. Secure in general all lifting points which are installed permanently, e.g. with glue.

- Please observe for the whole lifting mean the RUD sling chain safety instruction.

### 3.4 Hints for regular inspection

Lingering appropriateness of lifting means should be tested by a competent person, depending on the operational demands or at least once a year (see chapter 4 test criteria).

Depending on the operational demands, resulting from a numerous use, f.e. increased wear or corrosion, could make an earlier inspection necessary which means in a shorter interval than one year.

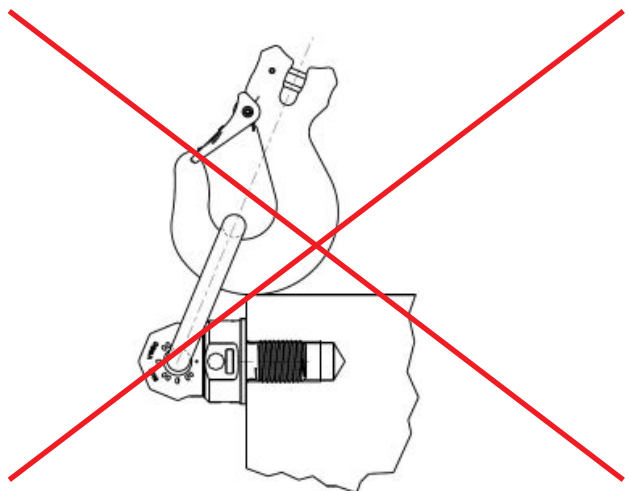

Pic. 2: Forbidden contact or support at/or with edge

## 4 Inspection criteria

Observe and control the following points before each initial operation, in regular time intervals, after the assembly and after special incidents.

- Correct bolt- and nut size plus thread engagement
- Solid bolt fixture - Inspection of bolting torque
- The bearing surface of the VWBG must lay plane and holohedral on the bolting area.
- Completeness of the lifting point
- Complete, readable WLL statements as well as manufacturer sign.
- Deformation at load bearing components like base body, suspension ring and threaded pin.
- Mechanical damage, like strong notches, especially in areas where tensile stress occurs.
- Fixed fit of side locking disc.
- Reduction of cross-section due to wear >10 %
- cracks or any other damage
- Function and damage of bolt threads and nuts
- Easy turning without jerk between upper and base part of the VWBG must be guaranteed.

- The maximum allowance for clearance of  $s = 4 \text{ mm}$ , between upper and base part must not be exceeded, respectively the proof groove in the ring connection must not be visible.

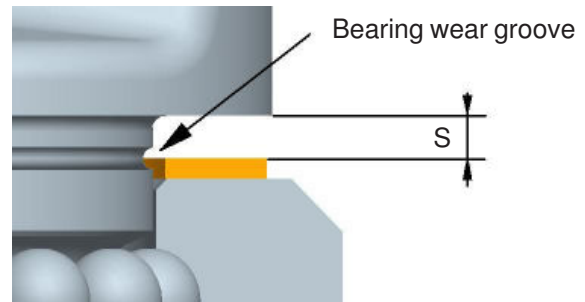

Pic. 5: Distance between upper and base part plus bearing wear groove

## 5 Hints for repairing

Repair work must only be carried out by a competent person at RUD or by a RUD trained and authorized service station, which has obtained the necessary knowledge and skills.

RUD-VWBGs are designed for a dynamical loading of 20.000 load cycles at nominal working load. The BG recommends: At a high dynamic loading with high numbers of load cycles (continuous work) the bearing stress acc. to FEM group 1Bm (M3 acc. to DIN 818-7) must be reduced.

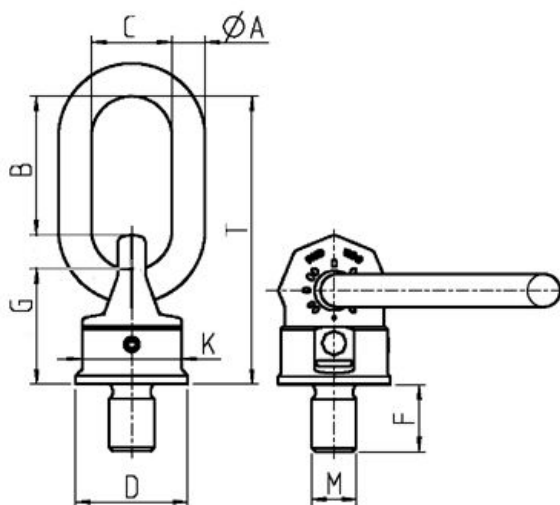

Pic. 3: Dimensioning of VWBG-Standard

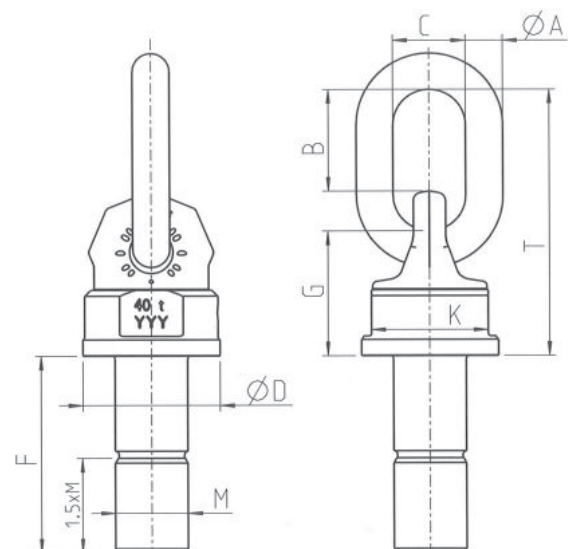

Pic. 4: Dimensioning of VWBG-Vario

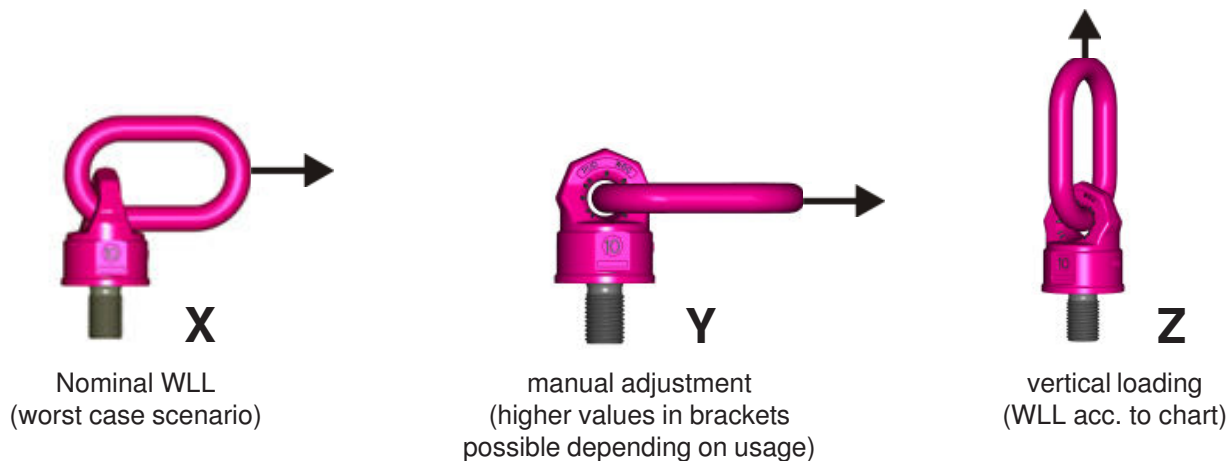

Pic. 6: Loading directions

## WLL overview

methode of lifting											
number of strands		1	2	1	2	2	2	2	3 / 4 *	3 / 4 *	3 / 4 *
inclination angle		0°	0°	90 °	90°	0-45°	45-60°	Un-symm.	0-45°	45-60°	Un-symm
Factor				1	2	1.4	1	1	2.1	1.5	1
Type	thread	For the max. total load weight >G< in metric tons, tightened and adjusted to force direction.									
VWBG 6(7.5)	M33	15	30	6 (7.5)	12 (15)	8.4 (10.5)	6 (7.5)	6 (7.5)	12.6 (15.75)	9 (11.25)	6 (7.5)
VWBG 8(10)	M36 1 1/2"	15	30	8 (10)	16 (20)	11.2 (14)	8 (10)	8 (10)	16.8 (21)	12 (15)	8 (10)
VWBG 12(13)	M42 1 3/4" - 1 7/8"	17	34	12 (13)	24 (26)	16.8 (18,2)	12 (13)	12 (13)	25.2 (27.3)	18 (19.5)	12 (13)
VWBG 12(15)	M45	18	36	12 (15)	24 (30)	16.8 (21)	12 (15)	12 (15)	25.23 (31.5)	18 (22,5)	12 (15)
VWBG 13(16)	M48 2"	18	36	13 (16)	26 (32)	18.2 (22.4)	13 (16)	13 (16)	27.3 (33.6)	19.5 (24)	13 (16)
VWBG 14(20)	M52	25	50	14 (20)	28 (40)	19.6 (28)	14 (20)	14 (20)	29.4 (42)	21 (30)	14 (20)
VWBG 16(22)	M56 2 1/4" - 2 1/2"	28	56	16 (22)	32 (44)	22.4 (30.8)	16 (22)	16 (22)	33.6 (46.2)	24 (33)	16 (22)
VWBG 16(25)	M64 2 3/4" - 3"	28	56	16 (25)	32 (50)	22.4 (35)	16 (25)	16 (25)	33.6 (52.5)	24 (37.5)	16 (25)
VWBG 31.5(40)	M72 3"	50	100	31.5 (40)	63 (80)	44.1 (56)	31.5 (40)	31.5 (40)	66.15 (84)	47.25 (60)	31.5 (40)
VWBG 35(48)	M80 3 1/2"	50	100	35 (48)	70 (96)	49 (67.2)	35 (48)	35 (48)	73.5 (100.8)	52.5 (72)	35 (48)
VWBG 40(50)	M90 4" - 5"	50	100	40 (50)	80 (100)	56 (70)	40 (50)	40 (50)	84 (105)	60 (75)	40 (50)

Chart 2

\* **Hint:** Stated WLL for 3-4 strands is only valid when it is guaranteed that the load is distributed equal to more than 2 strands. Otherwise the 2 strand values must be taken (see BGR 500 chapter 2.8 paragraph 3.5.3).



### ATTENTION

Please mind at the use especially that the method of lifting does not get changed

## Overview

Nomination	WLL [t]	A [mm]	B [mm]	C [mm]	D [mm]	F [mm]	Fvario [mm]	G [mm]	K [mm]	M [mm]	T [mm]	weight [kg/St]	Bolting-torque [Nm]	Ref.-No.:
VWBG 6(7,5) M33	6(7,5)	22	86	50	90	-	33-300	94	80	33	208	-	350	8600150
VWBG 8(10) M36	8(10)	22	86	50	90	54	-	94	80	36	208	4.6	410	7999059
VWBG 8(10) Vario	8(10)	22	86	50	90	-	36-300	94	80	36-39	208	-	410	8600451
VWBG 12(13) M42	12(13)	26	111	65	98	63	-	96	85	42	235	6.1	550	7999044
VWBG 12(13) Vario	12(13)	26	111	65	98	-	42-300	96	85	42-45	235	-	550	8600452
VWBG 12(15) M45	12(15)	26	111	65	98	67	-	96	85	45	235	6.2	550	7900455
VWBG 13(16) M48	13(16)	26	111	65	98	68	-	96	85	48	235	6.3	550	7999045
VWBG 13(16) Vario	13(16)	26	111	65	98	-	48-300	96	85	48-52	235	-	550	8600453
VWBG 14(20) M52	14(20)	32	119	70	120	78	-	120	95	52	274	10.5	750	7901081
VWBG 16(22) M56	16(22)	32	119	70	120	84	-	120	95	56	274	10.7	800	7999004
VWBG 16(22) Vario	16(22)	32	119	70	120	-	56-300	120	95	56-62	274	-	800	8600454
VWBG 16(25) M64	16(25)	32	119	70	120	94	-	120	95	64	274	11.4	800	7999043
VWBG 16(25) Vario	16(25)	32	119	70	120	-	64-300	120	95	64-76	274	-	800	8600455
VWBG 31.5(40) M72	31.5(40)	46	130	90	170	108	-	159	145	72	338	29.9	1200	7900097
VWBG 31.5(40) Vario	31.5(40)	46	130	90	170	-	72-300	159	145	72-76	338	-	1200	8600456
VWBG 35(48) M80	35(48)	46	130	90	170	120	-	159	145	80	338	31.2	1500	7900100
VWBG 35(48) Vario	35(48)	46	130	90	170	-	80-300	159	145	80-85	338	-	1500	8600457
VWBG 40(50) M90	40(50)	46	130	90	170	135	-	159	145	90	338	33.2	2000	7995545
VWBG 40(50) M90	40(50)	46	170	110	170	135	-	159	145	90	378	34.5	2000	7903408
VWBG 40(50) Vario	40(50)	46	130	90	170	-	90-300	159	145	90-150	338	-	2000	8600157
VWBG 40(50) Vario	40(50)	46	170	110	170	-	90-300	159	145	90-150	378	-	2000	8600458

Chart 3: Dimensioning

Subject to technical alterations