

Miller SkyGrip™ Temporary Horizontal Lifeline (HLL)

Description

The SkyGrip Temporary HLL System is a fall protection anchorage system designed to attach to a suitable anchor. The stanchions of the system are commonly attached to a steel beam or concrete beam/girder. Stanchion style systems include upright posts, or stanchions, that support a horizontal line. A worker, wearing a full-body harness and using a connecting device such as a shock-absorbing lanyard or self-retracting lifeline (SRL), connects to the lifeline of the system. The worker can then safely move horizontally.

Materials

Cable Lifeline:	Galvanized steel, 3/8" (9.5 mm) diameter (7x19 wire strand configuration.)
Stanchion Post:	Steel, yellow-zinc chromate finish
Steel Beam Modular Base:	Steel, yellow-zinc chromate finish
Crossbar:	Steel, yellow-zinc chromate finish
Crossbar Clamp:	Stainless Steel with nylon lanyard and zinc-plated steel quick-release pin
Concrete Beam Modular Base:	Steel with yellow-zinc chromate finish
Tie-Back Bracket:	Steel, yellow-zinc chromate finish
Slider Bracket:	Steel, yellow-zinc chromate finish
Rebar Clamp:	Steel, yellow-zinc chromate finish
Energy Absorber:	Stainless Steel. Limits forces to 2,500lbs (11kN) which provides 2:1 safety factor for 5,000 lbs. (22kN) Rated for 5,000lbs (22kN) at full extension.
Turnbuckle:	Galvanized steel. 5/8"-11, Jaw-to-Jaw style connection
Cable Clip:	Galvanized steel, double-saddle style
Combo. Clamp & Thimble:	Cast steel, corrosion-resistant painted finish
Pass-Thru Bracket:	Steel, yellow-zinc chromate finish
Tie-Back Chain:	Grade 80, high-strength galvanized steel
Chain Clevis:	Stainless Steel
Anchor Shackle:	7/16" Galvanized Steel with safety fasteners



Steel System Application



Concrete System Application

Miller SkyGrip™ Temporary Horizontal Lifeline (HLL)

Materials Continued

Carabiner:	Zinc Dichromate Plated Forged Alloy Steel Min. Tensile Strength: 5,000 lbs. (22kN)
Tensioner:	Stainless steel shaft and washers with zinc-plated clevis loop ends.
Anchor Shackle:	Galvanized steel, alloy steel pins with nut and safety cotter pin.
Steel Base Clamp Bolts:	Steel, yellow zinc, 3/4"-10 x 5" long grade 8 fully threaded.
Base Attachment Fasteners:	Clear zinc plated steel, 1/2"-13 x 5 1/2" long, grade 5 with 1/2" nylon lock nut.
Pass-Through Fasteners:	Clear zinc plated steel, 1/2"-13 x 3 1/4" long, grade 5 with 1/2" nylon lock nut.
Chain Connector Fasteners:	Clear zinc plated steel, 5/16"-18" x 1 1/4" long, grade 8 with 5/16" nylon lock nut.
V-Grip Fasteners:	Yellow Zinc plated steel, 1/2"-13 x 3 1/4" long, grade 8 fully threaded bolt with 1/2" split lock washer, flat washer and hex nut.
Slider Bracket Pins:	Stainless Steel with clear zinc plated steel hitch pin and 3/4" diameter washer.

Technical

Capacity:

Maximum span between stanchions: 60 ft (18m)

Maximum Capacity per Span: 2.

Maximum Capacity Per System (Steel): 6 Workers at 310 lbs (141kg) each.

Maximum Capacity Per System (Concrete): 5 Workers at 310 lbs. (141kg) each.

Steel Beam Size Requirements:

The SkyGrip is designed to be installed on a wide range of steel beams. The unique modular base accommodates beam flanges up to 2-1/4" (57mm) and widths from 4" (102mm) to 18" (457mm). [Optional large base and crossbar accommodates flange thicknesses from 2-1/4" (57mm) up to 3-3/8" (86mm) and widths from 12" (305mm) to 36" (914mm).]

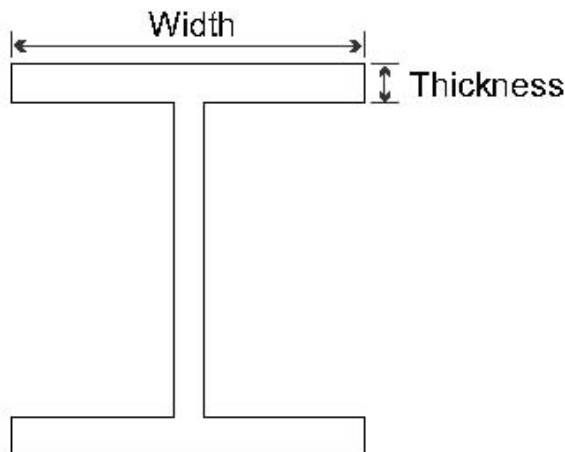

Miller SkyGrip™ Temporary Horizontal Lifeline (HLL)

Beam Loading Requirements

The steel or precast concrete beam(s) to which the SkyGrip is installed must be able to support the potential loads that may be applied in the event of a fall arrest. Stanchion posts may incur horizontal and vertical forces as well as torsional loads. Refer to beam load requirements below. Cumulative loading must be evaluated when more than one system is installed on a beam.

Steel Beams

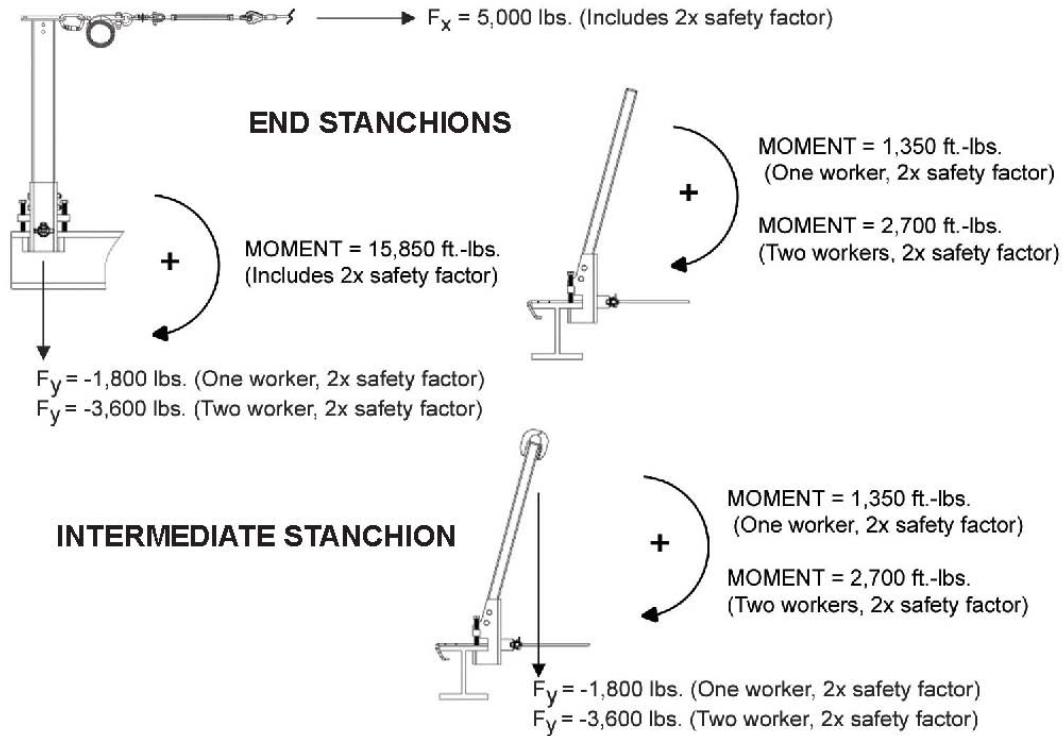

Concrete Beams

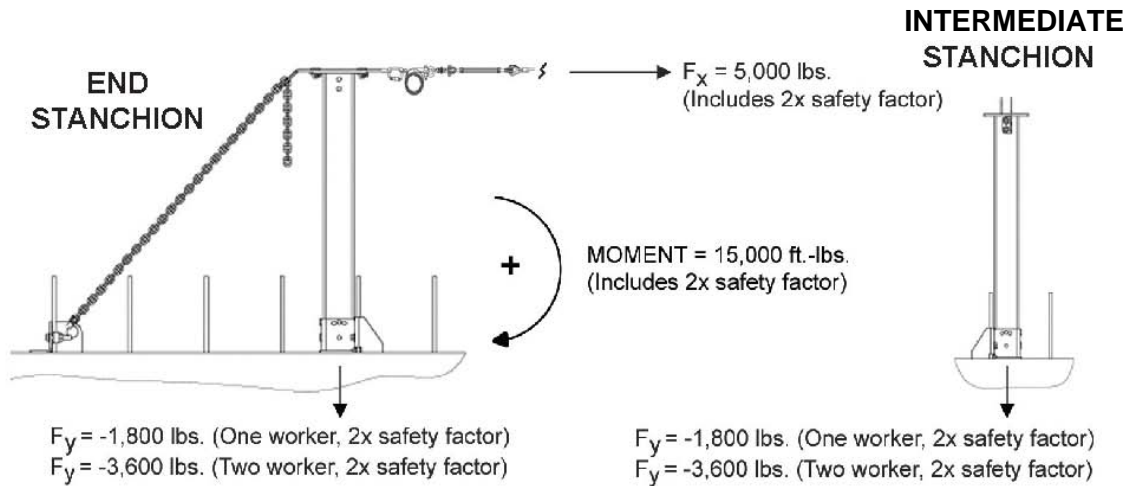

Miller SkyGrip™ Temporary Horizontal Lifeline (HLL)

Concrete Beam Attachment Methods

1. Rebar Spacing and Size Requirements

The concrete mounting base and tie-back bracket are designed to be installed to rebar in straight, L-shaped and U-shaped configurations with varied spacing.

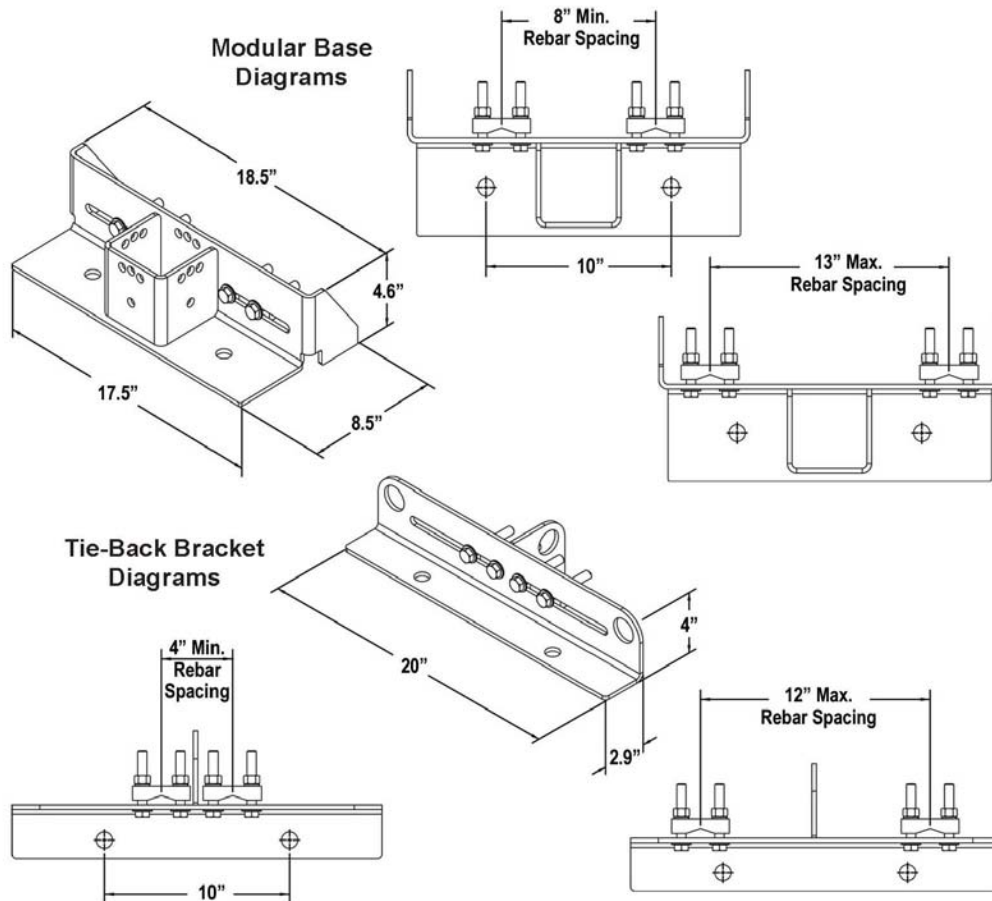

2. Coil Insert Requirements*

The concrete base and tie-back brackets can be mounted using coil-inserts such as the Dayton/Richmond (Dayton/Superior) B-18 Single-Flared Coil Inserts. Requirements: 3/4" x 9" coil inserts.

3. Concrete Expansion Anchor Bolt Requirements*

The concrete base and tie-back brackets can be mounted using concrete expansion anchor bolts such as the Hilti Kwik Bolt 3 Expansion Anchor, 3/4" x 4-3/4" length (Item No. 282517). This is a plated, carbon steel 3/4-10 UNC bolt with 1-1/2" thread length.

* Refer to manufacturer's instructions, installation procedures and required specifications.

Certification

Meets OSHA and ANSI A10.32-2004 requirements

Miller SkyGrip™ Temporary Horizontal Lifeline (HLL)

System Diagrams

For a Typical Single-Span system diagram, omit the Intermediate Stanchion*.

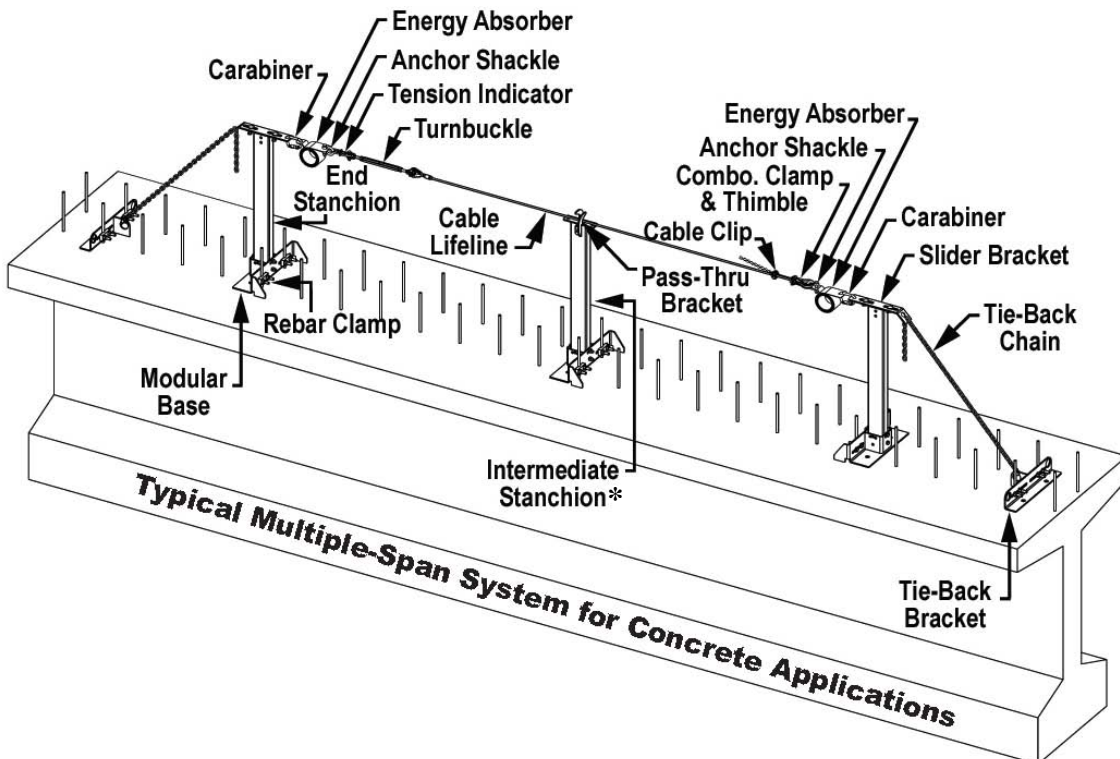
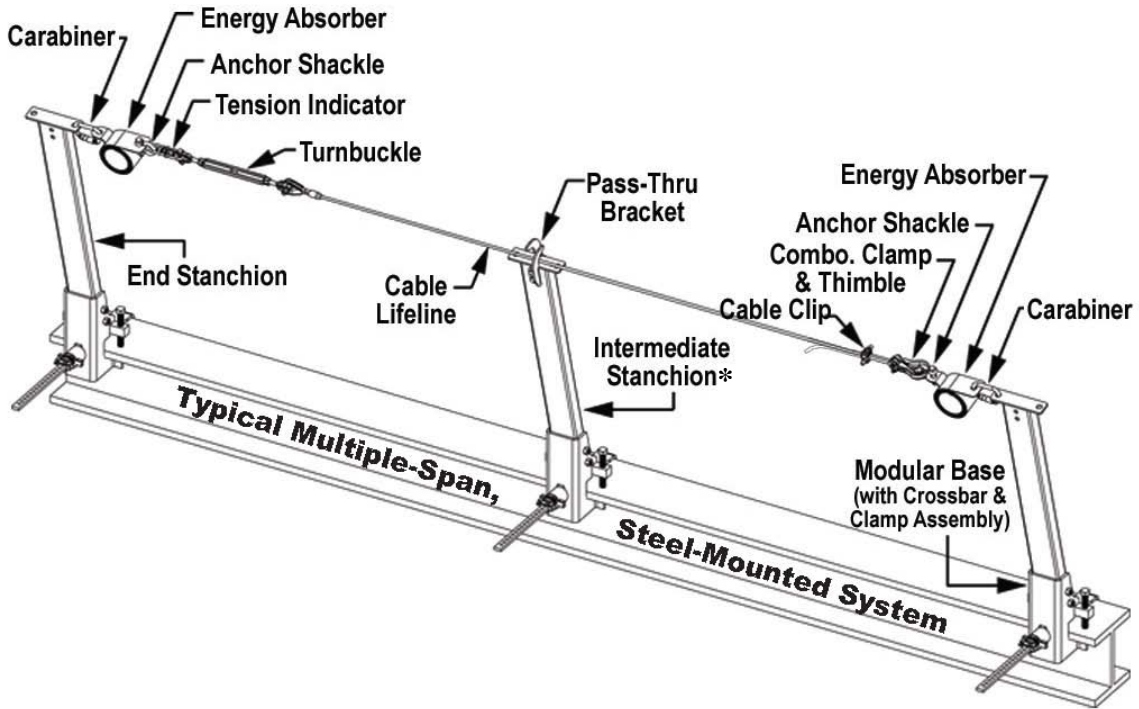

Miller SkyGrip™ Temporary Horizontal Lifeline (HLL)

Fall Clearance Charts/Diagrams

Always know your fall clearance before proceeding with the use of a horizontal lifeline system. Fall clearance calculations are based on the application of the system (steel or concrete mounted), length of span between stanchions, connecting device being used, and number of workers connected to the system within a span. Calculations are made from the working surface of the horizontal lifeline system. Miller Fall Protection recommends a 3 ft. (.9m) safety factor be added to all fall clearance calculations.

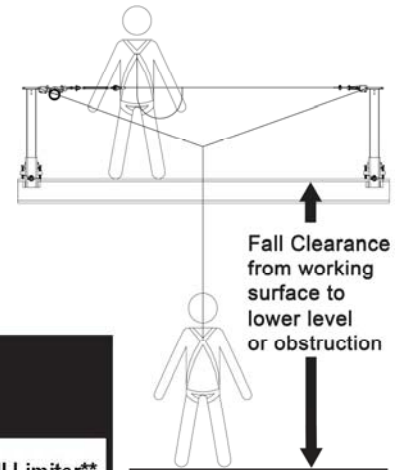

Total Fall Clearance Required* [ft.-in. (m)] for One or Two Workers Connected to Steel Mounted SkyGrip System (within a span)

Span Length [ft (m)]	Length of Lanyard								SRL/Fall Limiter**	
	3ft (.9m)		4ft (1.2m)		5ft (1.5m)		6ft (1.8m)			
	One Worker	Two Workers	One Worker	Two Workers	One Worker	Two Workers	One Worker	Two Workers	One Worker	Two Workers
0-10 (0-3m)	9'-8" (3m)	10'-8" (3.3m)	10'-8" (3.3m)	11'-8" (3.6m)	11'-8" (3.6m)	12'-8" (3.9m)	12'-8" (3.9m)	13'-8" (4.2m)	9'-8" (3m)	10'-8" (3.3m)
10-20 (3-6.1m)	10'-9" (3.3m)	11'-11" (3.6m)	11'-9" (3.6m)	12'-11" (3.9m)	12'-9" (3.9m)	13'-11" (4.2m)	13'-9" (4.2m)	14'-11" (4.6m)	10'-9" (3.3m)	11'-11" (3.6m)
20-30 (6.1-9.1m)	11'-8" (3.6m)	13'-2" (4m)	12'-8" (3.9m)	14'-2" (4.3m)	13'-8" (4.2m)	15'-2" (4.6m)	14'-8" (4.5m)	16'-2" (4.9m)	11'-8" (3.6m)	13'-2" (4m)
30-40 (9.1-12.2m)	12'-9" (3.9m)	14'-5" (4.4m)	13'-9" (4.2m)	15'-5" (4.7m)	14'-9" (4.5m)	16'-5" (5m)	15'-9" (4.8m)	17'-5" (5.3m)	12'-9" (3.9m)	14'-5" (4.4m)
40-50 (12.2-15.2m)	13'-8" (4.2m)	15'-8" (4.8m)	14'-8" (4.5m)	16'-8" (5.1m)	15'-8" (4.8m)	17'-8" (5.4m)	16'-8" (5.1m)	18'-8" (5.7m)	13'-8" (4.2m)	15'-8" (4.8m)
50-60 (15.2-18.3m)	14'-9" (4.5m)	17'-1" (5.2m)	15'-9" (4.8m)	18'-1" (5.5m)	16'-9" (5.1m)	19'-1" (5.8m)	17'-9" (5.4m)	20'-1" (6.1m)	14'-9" (4.5m)	17'-1" (5.2m)

Total Fall Clearance Required* [ft.-in. (m)] for One or Two Workers Connected to Concrete Mounted SkyGrip System (within a span)

Span Length [ft (m)]	Length of Lanyard								SRL/Fall Limiter**	
	3ft (.9m)		4ft (1.2m)		5ft (1.5m)		6ft (1.8m)			
	One Worker	Two Workers	One Worker	Two Workers	One Worker	Two Workers	One Worker	Two Workers	One Worker	Two Workers
0-10 (0-3m)	9'-8" (3m)	11'-4" (3.5m)	10'-8" (3.3m)	12'-4" (3.8m)	11'-8" (3.6m)	13'-4" (4m)	12'-8" (3.9m)	14'-4" (4.4m)	9'-8" (3m)	11'-4" (3.5m)
10-20 (3-6.1m)	10'-9" (3.3m)	12'-5" (3.8m)	11'-9" (3.6m)	13'-5" (4.1m)	12'-9" (3.9m)	14'-5" (4.4m)	13'-9" (4.2m)	15'-5" (4.7m)	10'-9" (3.3m)	12'-5" (3.8m)
20-30 (6.1-9.1m)	11'-8" (3.6m)	13'-5" (4.1m)	12'-8" (3.9m)	14'-5" (4.4m)	13'-8" (4.2m)	15'-5" (4.7m)	14'-8" (4.5m)	16'-5" (5m)	11'-8" (3.6m)	13'-5" (4.1m)
30-40 (9.1-12.2m)	12'-9" (3.9m)	14'-5" (4.4m)	13'-9" (4.2m)	15'-5" (4.7m)	14'-9" (4.5m)	16'-5" (5m)	15'-9" (4.8m)	17'-5" (5.2m)	12'-9" (3.9m)	14'-5" (4.4m)
40-50 (12.2-15.2m)	13'-8" (4.2m)	15'-5" (4.7m)	14'-8" (4.5m)	16'-5" (5m)	15'-8" (4.8m)	17'-5" (5.2m)	16'-8" (5.1m)	18'-5" (5.6m)	13'-8" (4.2m)	15'-5" (4.7m)
50-60 (15.2-18.3m)	14'-9" (4.5m)	16'-6" (5m)	15'-9" (4.8m)	17'-6" (5.3m)	16'-9" (5.1m)	18'-6" (5.6m)	17'-9" (5.4m)	19'-6" (5.9m)	14'-9" (4.5m)	16'-6" (5m)

*Miller Fall Protection recommends that a 3ft (.9m) safety factor be added to the above fall clearance calculations.

**The SRL/Fall Limiter clearance calculations assume the worker is located directly adjacent to the lifeline where the SRL/Fall Limiter is connected. Working away from the point of attachment increases fall clearance.

Miller SkyGrip™ Temporary Horizontal Lifeline (HLL)

Fall Clearance for HLL Kits

The following fall clearance chart applies when using SkyGrip Horizontal Lifeline kits. Because the lifeline kits may be mounted at different heights over the working surface, calculations are made from the lifeline. Miller Fall Protection recommends a 3 ft. (.9m) safety factor be added to all fall clearance calculations.

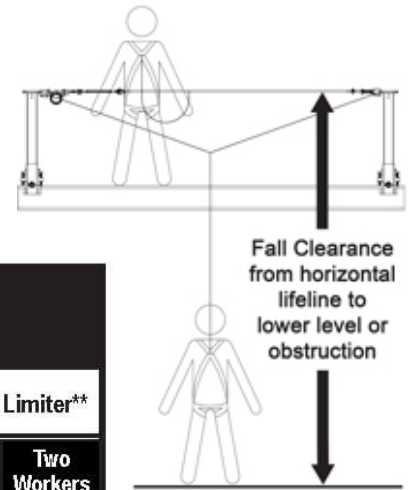

Total Fall Clearance Required* [ft.-in. (m)] for One or Two Workers using SkyGrip Horizontal Lifeline Kits

Span Length [ft (m)]	Length of Lanyard								SRL/Fall Limiter**	
	3ft (.9m)		4ft (1.2m)		5ft (1.5m)		6ft (1.8m)			
	One Worker	Two Workers	One Worker	Two Workers	One Worker	Two Workers	One Worker	Two Workers	One Worker	Two Workers
0-10 (0-3m)	13'-2" (4m)	14'-1" (4.3m)	14'-2" (4.3m)	15'-1" (4.6m)	15'-2" (4.6m)	16'-1" (4.9m)	16'-2" (4.9m)	17'-1" (5.2m)	13'-2" (4m)	14'-1" (4.3m)
10-20 (3-6.1m)	13'-11" (4.2m)	15'-0" (4.6m)	14'-11" (4.5m)	16'-0" (4.9m)	15'-11" (4.9m)	17'-0" (5.2m)	16'-11" (5.2m)	18'-0" (5.5m)	13'-11" (4.2m)	15'-0" (4.6m)
20-30 (6.1-9.1m)	14'-8" (4.5m)	16'-0" (4.9m)	15'-8" (4.8m)	17'-0" (5.2m)	16'-8" (5.1m)	18'-0" (5.5m)	17'-8" (5.4m)	19'-0" (5.8m)	14'-8" (4.5m)	16'-0" (4.9m)
30-40 (9.1-12.2m)	15'-5" (4.7m)	16'-11" (5.2m)	16'-5" (5m)	17'-11" (5.5m)	17'-5" (5.3m)	18'-11" (5.8m)	18'-5" (5.6m)	19'-11" (6.1m)	15'-5" (4.7m)	16'-11" (5.2m)
40-50 (12.2-15.2m)	16'-2" (4.9m)	17'-11" (5.5m)	17'-2" (5.2m)	18'-11" (5.8m)	18'-2" (5.5m)	19'-11" (6.1m)	19'-2" (5.8m)	20'-11" (6.4m)	16'-2" (4.9m)	17'-11" (5.5m)
50-60 (15.2-18.3m)	16'-11" (5.2m)	18'-10" (5.7m)	17'-11" (5.5m)	19'-10" (6m)	18'-11" (5.8m)	20'-10" (6.4m)	19'-11" (6.1m)	21'-10" (6.7m)	16'-11" (5.2m)	18'-10" (5.7m)

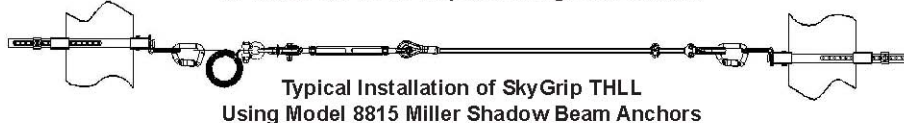
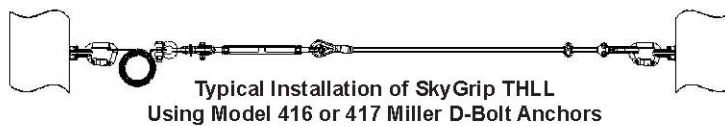
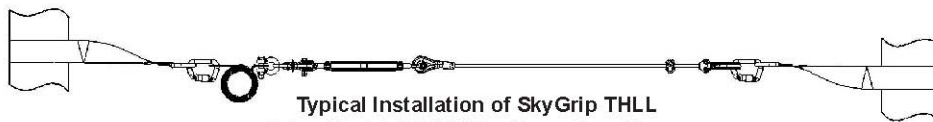

Toll Free 800.873.5242 • Phone 814.432.2118 • Fax 800.892.4078 • www.millerfallprotection.com

WARNING! THIS DOCUMENT PROVIDES AN OVERVIEW OF FALL PROTECTION PRODUCTS AVAILABLE FROM MILLER FALL PROTECTION AND CARE HAS BEEN TAKEN TO ASSURE THE ACCURACY OF THE DATA. IT DOES NOT PROVIDE IMPORTANT PRODUCT WARNINGS AND INSTRUCTIONS. MILLER FALL PROTECTION RECOMMENDS ALL USERS OF FALL PROTECTION EQUIPMENT UNDERGO THOROUGH TRAINING, AND THAT ALL WARNINGS AND INSTRUCTIONS PROVIDED WITH THE PRODUCTS BE THOROUGHLY READ AND UNDERSTOOD PRIOR TO EACH USE. FAILURE TO READ AND FOLLOW ALL PRODUCT WARNINGS AND INSTRUCTIONS COULD RESULT IN SERIOUS INJURY OR DEATH.