

Dayton Sump Pumps

PUMPS technical data sheet



Sink pump systems remove above-grade water from residential and commercial applications. These systems are a compact combination of an automatic float switch, a pump and a small basin. They collect water from lavatory basins, sinks or laundry tubs, where a sump or basin installation is not feasible. The wastewater collected in the small sink pump system basin is then pumped out to a larger basin or sump for final removal.



12F740 1/2 HP, Cast Iron Sink Pump System

HP	1/2
Voltage	115V
Phase	Single
Frequency	60 Hz
Run Amps	4.9A
RPM	3450
Motor Type	PSC – Oil Filled
Overload Protection	Internal Thermal Overload
Motor Shaft Material	Stainless Steel
Motor Housing Material	Cast Iron
Motor Duty	Intermittent

Motor End Bearing	Single Row Ball
Pump End Bearing	Single Row Ball
Lubrication	Oil Lubricated
Discharge	1-1/2 Inch FNPT, Vertical
Volute Material	Cast Iron
Base Material	Cast Iron
Impeller Type	Vortex
Impeller Material	Stainless Steel
Hardware Material	Stainless Steel
O-rings	Buna-N
Seal Type	Single Mechanical
Seal Materials	Carbon/Ceramic/Buna-N
Operation	Automatic / Vertical Switch
Power Cord	18/3 SJTW, 10' (3m), NEMA 5-15P 115V Plug
Max. Solids Handling	3/8" (9.5mm) spherical
Max. Water Temperature	140°F / 60°C
Designed Fluid Environment	Water / Wastewater
Switch Type	Vertical
Switch Cord	10' (3m) SJTOW Power Cord
Switch Plug	NEMA 5-15P Piggyback Plug
Switch Max. Run Amps	10A
Switch Max. Start Amps	60A
Switch Pumping Range	On at 7" (178mm) Off at 2" (51mm)
Basin Height	13-3/8" (340mm)
Basin Capacity	6 Gallons (22.7L)
Basin Material	High Density Polyethylene Structural Foam
Basin Discharge	1-1/2 Inch FNPT, Vertical
Basin Hardware Material	Zinc Plated Steel

Outline Dimensions

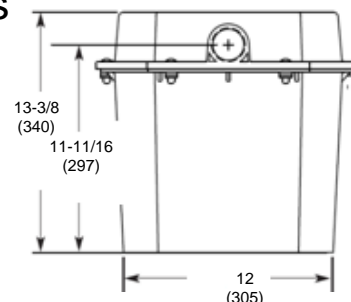
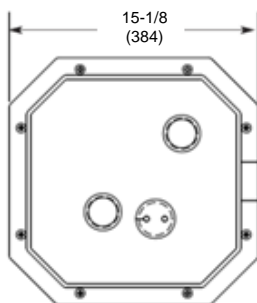

Performance Data

Head	Feet	5	10	15	20	25	26
	Meters	1.5	3.0	4.6	6.1	7.6	7.9
Flow Rate	GPM	42	38	32	24	5	0
	LPM	159	144	121	91	19	0

Performance Chart

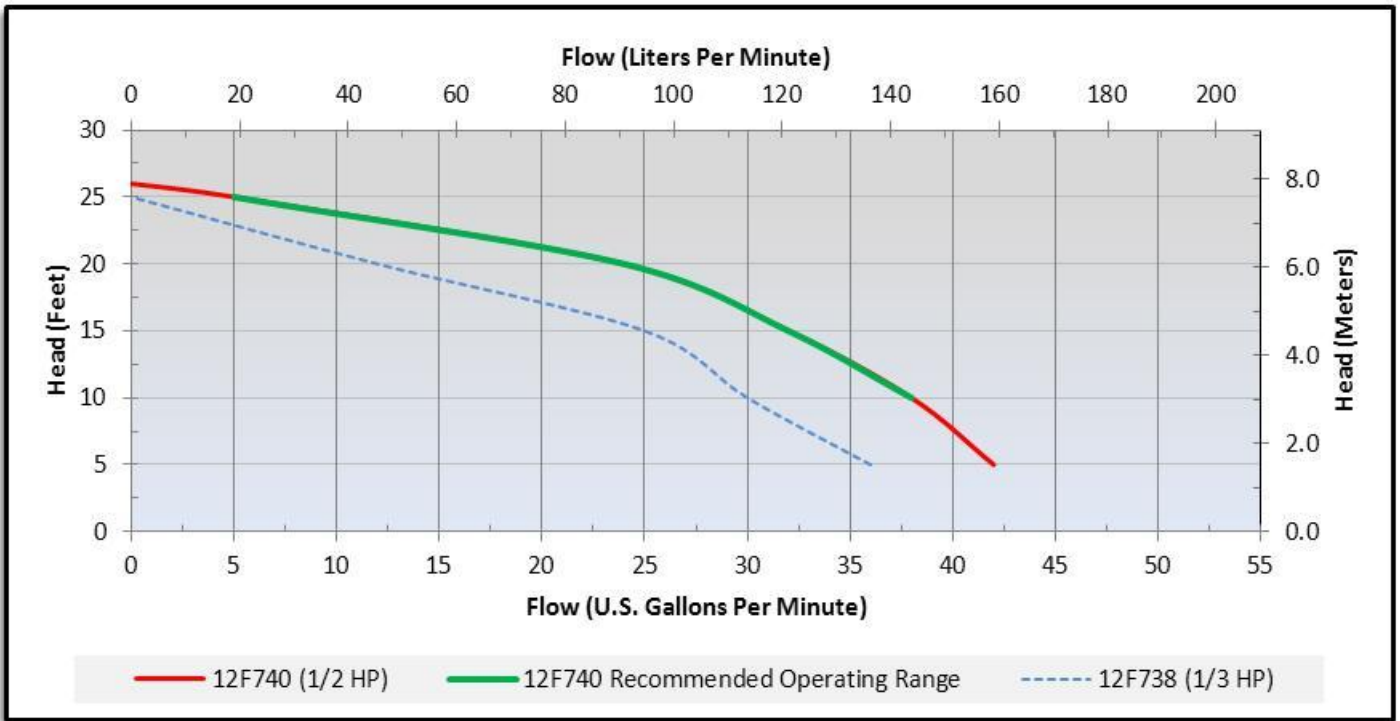

WARNING: Use only with nonflammable liquids compatible with pump component materials and in nonflammable/nonexplosive atmospheres.

Call or visit your local branch or go to grainger.com/dayton for complete product line information

Find it at Grainger.

© 2013 W.W. Grainger, Inc.

