



Chase Doors

World's Leading Manufacturer Of Traffic Doors
Cincinnati Ohio, and Redmond Oregon
Phone Toll Free: 1-800-543-4455
Fax: 1-800-285-0126
www.chasedoors.com

SD2000 SERIES, ABS5000, & SC3000 SERIES WINDOW INSTALLATION INSTRUCTIONS

DRAWN BY: J.C. DATE:10/27/05

STEP - 1. WEATHERSTRIP MOLDING INSTALLATION

- a.) INSTALL WEATHERSTRIP MOLDING (GROOVE "B") INTO WINDOW CUT-OUT IN PANEL AS SHOWN IN DETAILS TO THE RIGHT. MAKE SURE THAT WEATHERSTRIP MEETS AT TOP OF CUT-OUT. SLIGHT TRIMMING OF WEATHERSTRIP MAY BE NECESSARY, BUT SHOULD FIT TIGHTLY TO PREVENT A GAP AFTER WINDOW IS INSTALLED.
- b.) LUBRICATE RUBBER MOLDING WITH SPRAY GLASS CLEANER. INSERT $\frac{1}{4}$ " ACRYLIC WINDOW INTO GROOVE "A" OF RUBBER MOLDING UTILIZING STRAIGHT END OF WINDOW INSTALLATION TOOL.

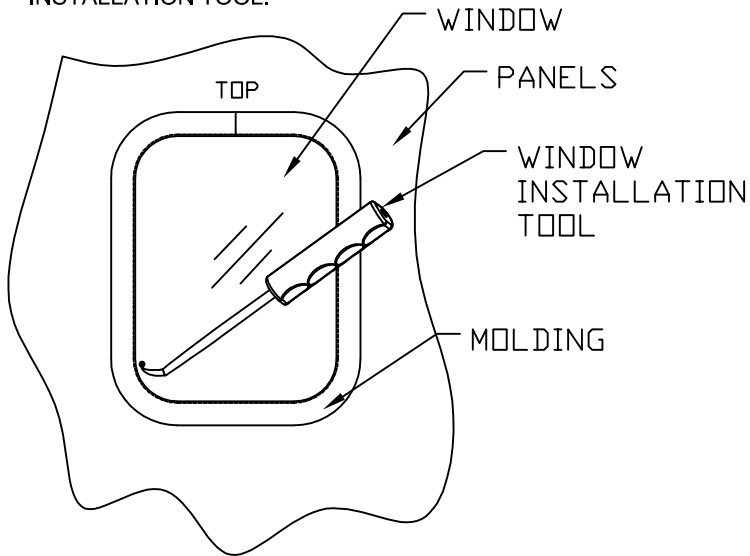

SD2000 SERIES

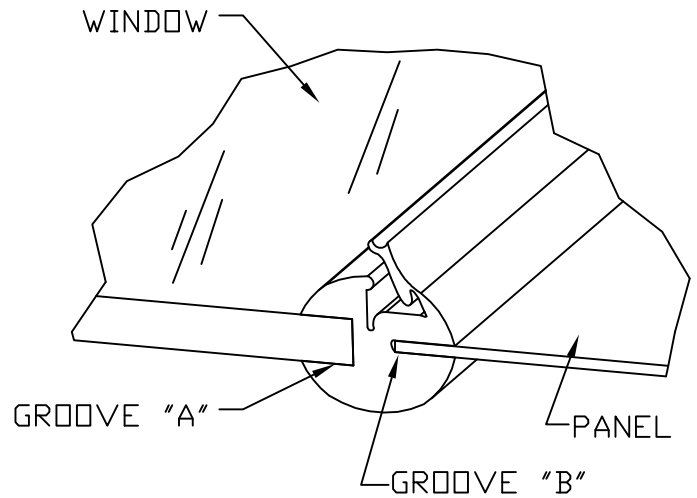

ABS 5000

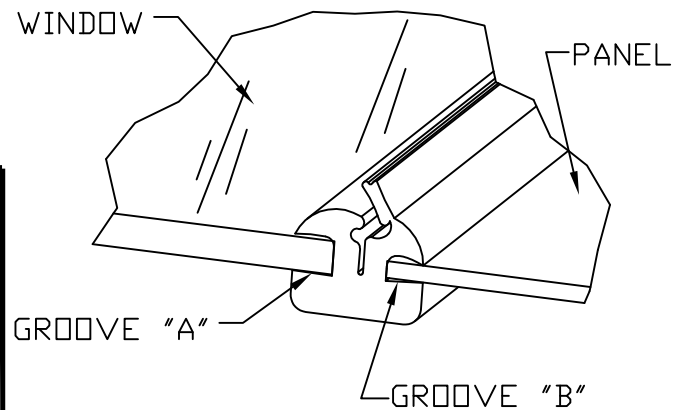

SC3000 SERIES

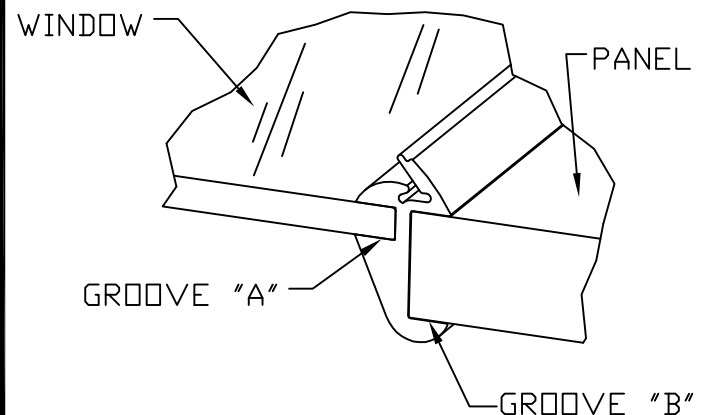

STEP - 2. USING WINDOW INSTALLATION TOOL

USING CURVED END OF WINDOW INSTALLATION TOOL, LOCK PANEL SIDE OF MOLDING UNDER WINDOW SIDE OF MOLDING, CLEAN WINDOW WITH GENERAL PURPOSE GLASS CLEANER AND SOFT CLOTH.

