



"E-Hinge" Installation Instructions

STEP #1

Check door jamb and header for plumb and squareness before beginning installation (See "Figure 1-A"). **Opening must be square and plumb for proper operation.** Minimum jamb width to be 4-1/2", with a minimum double 2X4 wood construction or equivalent. Hollow metal jambs must be reinforced at hinge locations.

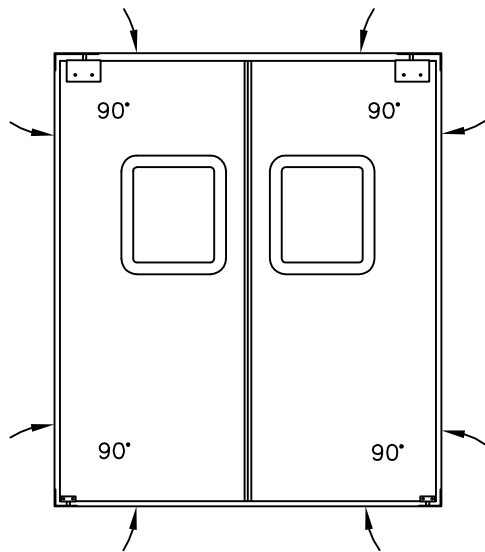

Figure 1-A

STEP #2

Remove both side covers from top hinge (E-Hinge). Remove the two nuts and bolts from the hinge as shown in "Figure 2-A". Using the top "L" bracket as a template, center the bracket on the jamb and header (See Figure 2-B), mark and drill the six holes (7/32" for steel, 3/16" for wood). Place "L" bracket in it's proper location, centered in jamb, and insert mounting screws provided (See "Figure 2-B").

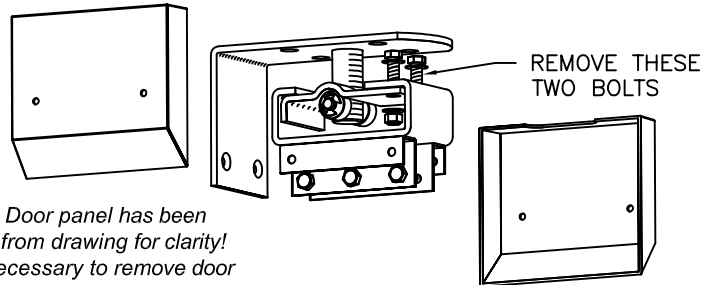

Figure 2-A

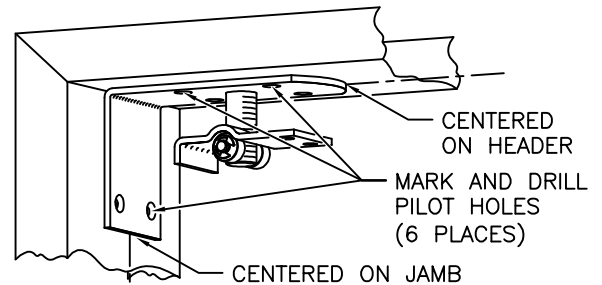

Figure 2-B

STEP #3

Install lower hinge pin to center of jamb (at floor) using self-drilling/tapping screws provided (See "Figure 3-A"). **NOTE: Lower Hinge Pin must be Plumb with upper hinge for proper swing and operation.** Install floor anchors/bolts (not provided).

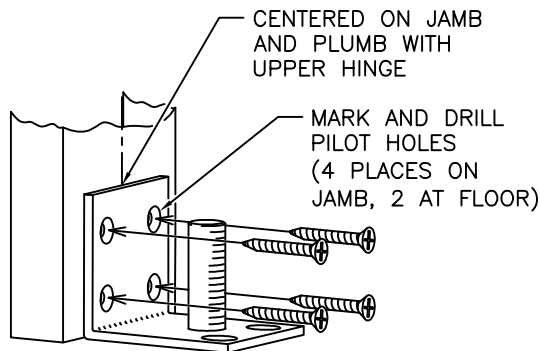

Figure 3-A

STEP #4

Position door panel upright and place over Lower Hinge Pin (See Step 3). Reinstall door panel to the "L" Bracket (See Step 2, Figure 2-B) of the "E-Hinge" and replace the two nuts and bolts which were removed in "Step 2" (Do Not Tighten At This Time). Align door panel to the desired position for proper operation and tighten nuts and bolts. Replace side covers to "E-Hinge".

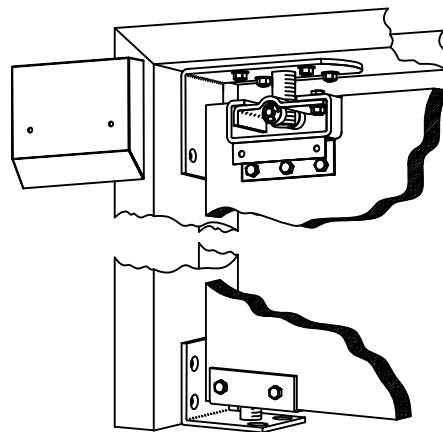

Figure 4-A